

New Construction

Series 5300 Garden Window Installation Instructions



Installation Requires Knowledge of:

- AAMA Installation Instructions.
- Applicable Federal, State, Local Codes and Regulations.
- An Understanding of the Fundamentals of Residential Construction.
- A Working Knowledge of the Tools, Equipment and Methods Required for Installation.
- A Familiarity with Caulking, Sealing Procedures and Glass Handling Procedures.

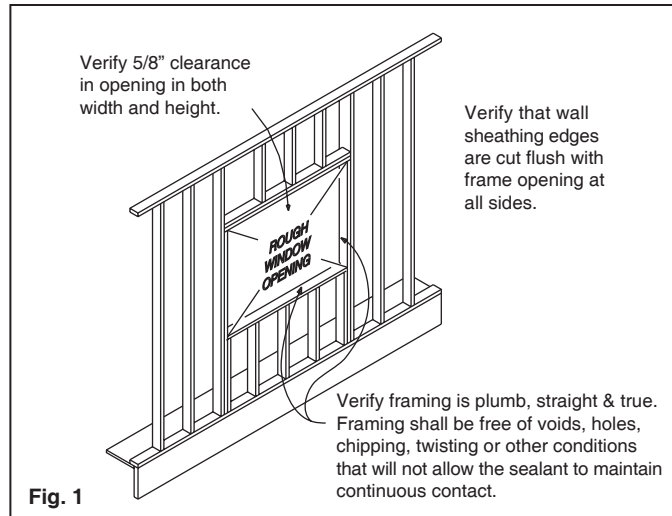

INSTALLATION NOTES:

- Responsibility for protecting any flashing material from damage caused by weather, other trades or vandalism and properly integrating the flashing system into the weather resistive barrier for the entire building will be the responsibility of the general contractor or his designated agent.
- Flashing and/or an appropriate method of sealing shall be designed as a part of an overall weather resistive barrier system. It is not the responsibility of the window manufacturer to design or recommend a flashing system appropriate to each job condition.
- Caution shall be used to avoid damage to windows before, during and after installation. Windows should be stored in a near vertical position in a clean area protected from exposure to weather elements.
- Any damage to the window frame joint seals or mounting flange must be repaired by the installer. Before installation, the sill track must be able to hold water for 15 minutes without leaking to the interior.
- Use sealant that conforms to AAMA 800-92 or sealant approved by the sealant manufacturer for the appropriate application.
- Field applied protective coatings can damage insulated glass, sealants, vinyl and gaskets. These are not recommended and will void the warranty. Stucco or concrete left on frames and glass will damage these surfaces. If any type of film or tinting material is applied to the glass surface, it could result in damage and voids the window warranty. Remove all material from surfaces before any curing action takes place.

Tools and Materials You Will Need

A few simple hand tools will aid in installation. Refer to the specific installation method instructions for materials required.

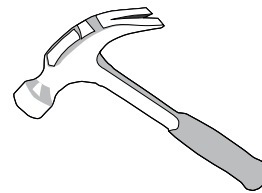

Hammer

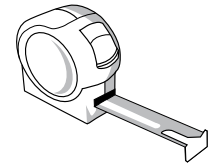

Tape Measure



Broad Wood Chisel

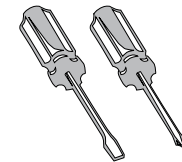

Flat and Phillips-head Screwdrivers



Utility Knife

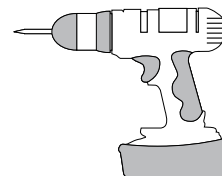

Drill

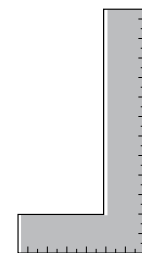

Square

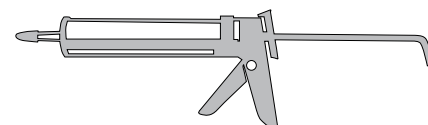

Caulking Gun



Level

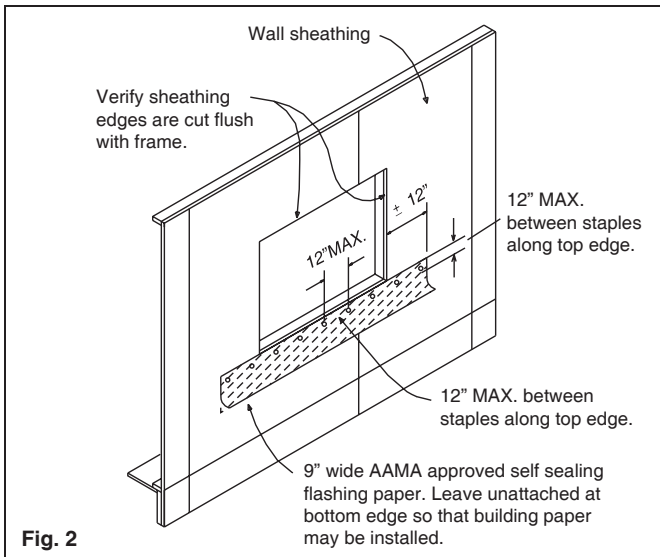

Fig. 2

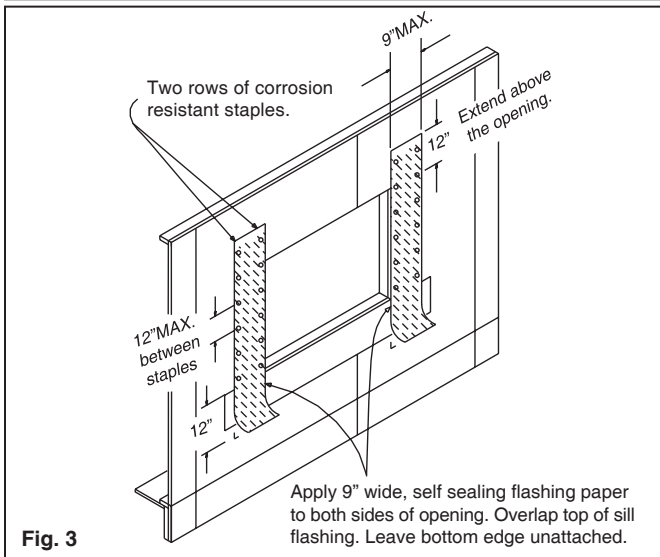

Fig. 3

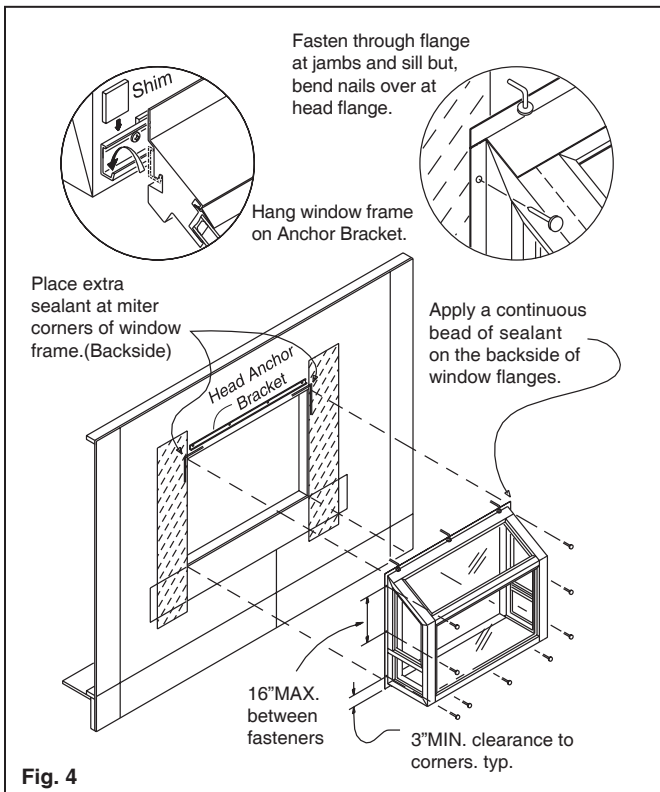

Fig. 4

- Flashing material shall be barrier coated reinforced and shall provide twenty-four (24) hour minimum protection from water penetration when tested in accordance with ASTM D-779. Flashing material shall carry continuous identification.

- Sealing/caulking required between the window and the flashing can be approved by the sealant/flashing manufacturer. Following their printed application procedures.

- Clean and lubricate hardware components with corrosion resistant spray or lubricant monthly to ensure proper performance. Silicone lubricant spray can be used on all operable components.

GUIDELINES IN ADDITION TO THE ABOVE.

Vinyl is an excellent material and is very durable, however, it must be handled differently than aluminum.

- With a vinyl structure of this size, additional support from underneath is required. Support must run the full width of the sill, to keep it from bowing in warm weather. Consider your option of using metal or wood braces. Method of support is supplied by others.

- Vinyl products must not be dropped on the corner of the nailing fin or hit against hard objects (damage will occur). With the vent removed or open, carry the window with two hands, one on the fixed jamb and one on the mullion.

- With vinyl products, the full width of the window sill must be fully supported during storage. Store in a shaded area vertically and on a flat surface.

1. REVIEW AND MEASURE THE OPENING

Verify rough window opening size has 5/8" clearance in both width and height to the new window. Verify framing is plumb, straight and true around window opening. See Fig. 1.

2. INSTALL FLASHING

Verify that wall sheathing edges are cut flush with frame opening at all sides. Use 9" wide approved flashing paper for sill flashing below window. Extend paper past the opening about 12" on both sides. See Fig. 2. Staple paper along the top edge where they will be covered by the mounting flange of the window. Staples should be no more than 12" apart. Corrosion resistant staples may be stainless steel or copper, with 3/8" leg for window flashing. Leave unattached at bottom edge so that building paper may be installed underneath.

Staple 9" wide, self sealing flashing paper to each jamb of the opening. Extend jamb paper about 12" beyond the opening at both head and sill. Overlap sill flashing with jamb paper, leaving bottom edge and lower portion unattached so that building paper may be installed underneath later. See Fig. 3.

3. INSTALL THE WINDOW FRAME AND FLASHING

A Head Anchor Bracket is supplied to ease the frame installation. The bracket slips into a recess and hooks the head portion of the frame, supporting the window for installation. Determine the proper height to install the Head Anchor Bracket to the exterior head portion of the rough opening, see Fig. 4. When installing the Head Anchor Bracket, the surface should be straight, flat and plumb. Shim behind the bracket if necessary.

The Garden Window will need to be supported from underneath, so keep in mind the method you will be using during the installation.

Apply a generous and continuous bead of sealant to the backside of the window flanges at head, jambs and sill. Use an appropriate sealant for the type of materials and building condition you are working with. Install frame into the opening while applying moderate pressure to the frame. Close and lock the window. Use shims to set frame level, square and plumb. Provide continuous support under sill with shims on ALL products. Caution must be taken to avoid disrupting the continuous seal of taut of 3 fasteners per side of frame. Fasteners should be no more than 16" apart and no less than 3" in from corners. See **Fig. 4**. Use corrosion resistant fasteners that are 6d in size or equal. Avoid overdriving fasteners. Use an appropriately sized fastener to cover the width of any pre-punched hole and adequately secure the window to the structure.

Apply a full length, continuous bead of sealant, to the rear, upright wall of the sill pan. This bead will make contact with the frame to create an air seal along the back side of the window and sill condition.

If any damage to window frame, joint seals or mounting flange is observed during installation, the installer must repair it. DO NOT nail through fin at head of frame. Instead, fasten nails 1/2" above fin and bend nail over fin to secure. This allows for frame expansion. When storing a vinyl product, provide support along the full length of the sill to avoid warping or sagging. DO NOT use expanding foam to insulate around the frame.

Install 15" wide R-15 underlayment over the jamb flanges of the window frame. See **Fig. 5**. Extend underlayment about 10" to 12" beyond the opening at both head and sill. Apply a continuous bead of a suitable sealant along the jamb flanges of the frame. Leave the bottom portion that extends below the sill unattached, so that building paper may be installed underneath. Lay the jamb flashing on the sealant and flanges, then secure edges with staples.

Attach 9" wide, AAMA approved, flashing paper to head area above the window. Paper should extend about 12" beyond the opening on both ends and overlap jamb flashing. Staple only along TOP edge of paper. Apply a continuous bead of a suitable sealant along head flange and vertical joints of jamb flashing. See **Fig. 6**. Lower head flashing paper over sealant and head flange. Secure with staples.

4. EXTERIOR FINISH

Where recommended as parts of exterior wall finish system, install building paper. Apply weatherboard fashion, starting at the bottom and work up to the top of the wall. Install building paper, insulation board or other materials OVER head flashing and nail-on flange of window frame. Slip bottom of jamb and sill flashing over building paper at bottom of window sill. See **Fig. 7**. Apply a continuous bead of an appropriate sealant along the full perimeter where paper and frame meet.

Apply exterior wall finish as per manufacturer's recommendation. Some exterior finishes may require sealing between the perimeter of the window frame and the exterior finish.

Install the under sill support braces at this time. It is crucial that support braces be installed and the support frame must run the full length of the sill to keep the front panel from bowing in warmer climates, see **Fig. 8**.

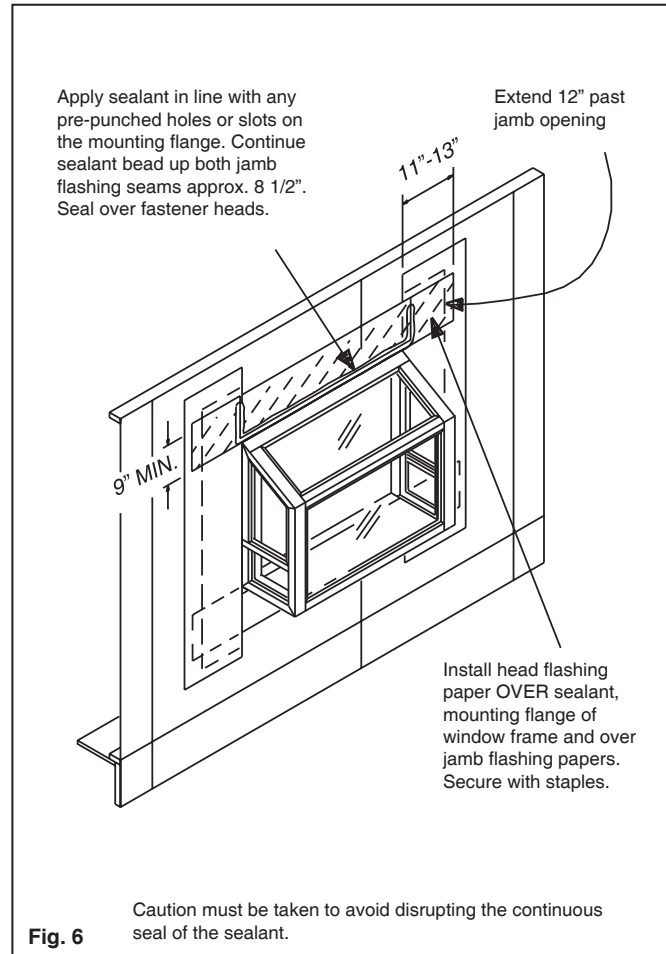
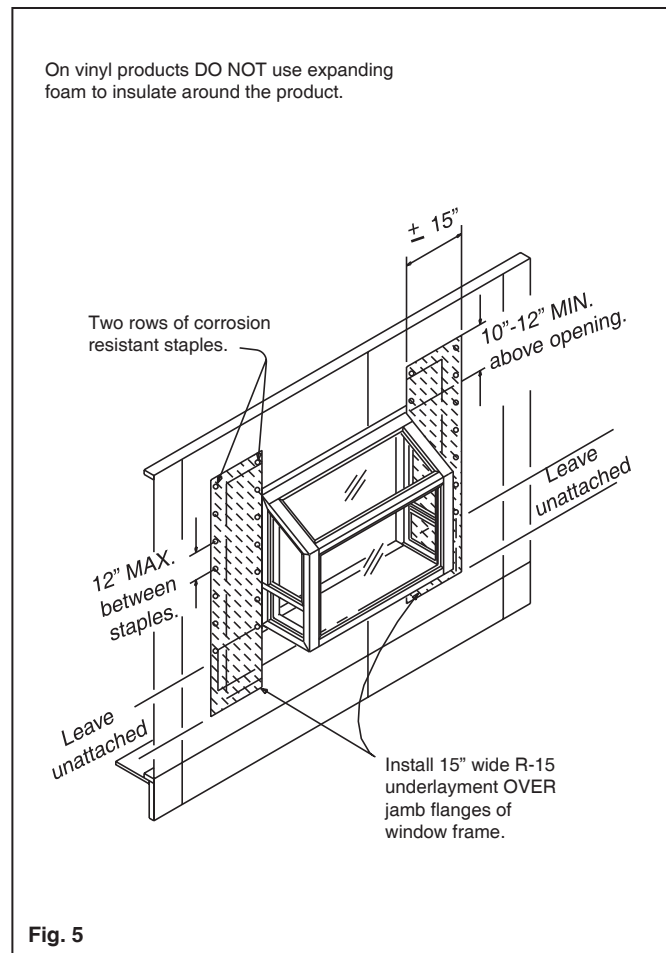

Where recommended as part of the exterior wall nish system, install building paper. Apply weather board fasteners starting from bottom to top of wall.

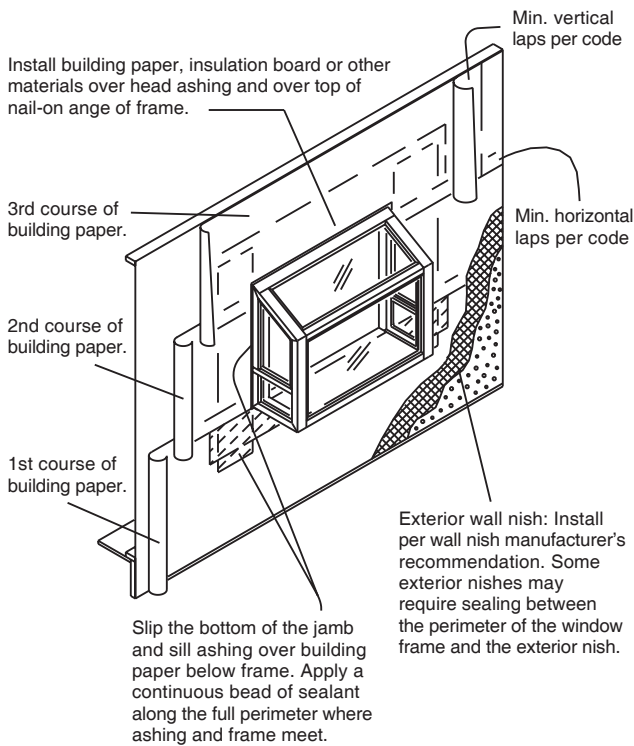

Fig. 7

Support material supplied by other.

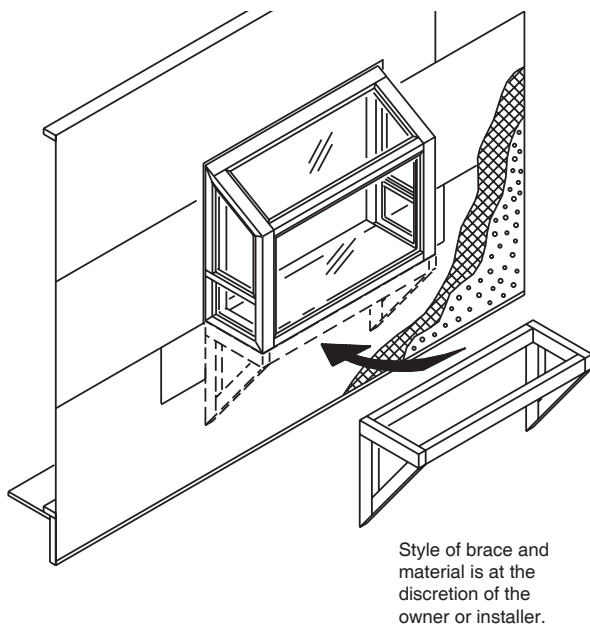

Fig. 8

- Wood trim, plant-ons, and pot shelves all require special precautions. When necessary under these conditions use metal flashing. Use metal flashing on any surfaces where water may not drain promptly.

- Seal all holes in the building paper including those caused by staples or nails.

- Interfaces between our products, flashing and the building's weather resistive barrier must be sealed with a sealant recommended for this application. We cannot recommend a particular type or manufacturer of sealant.

- Mulled windows require special treatment. Please consult instructions for your mulled conditions.

- Holes drilled for alarms may not be placed on sills or heads and must be sealed.

- Extreme weather conditions may cause water intrusion into your home and subsequent water damage. Consult a licensed engineer for an appropriate rating for expected local weather conditions.

- Do not apply film or tints to the surface of the glass. These products can cause insulated unit failure.

- To avoid the effects of electrolysis and chemical reaction to an aluminum sill, apply bituminous paint to raw masonry or concrete. You may also use a PVC liner to separate the metal frame from the substrate.

SEMI-ANNUAL MAINTENANCE

- Improperly maintained products will reduced the performance of any window or door. The sills and weeps must be cleaned regularly to allow for drainage. Water in the sill during a rainstorm is normal.

- Weather-strip should be cleaned and fluffed on a regular basis. Wearing of the wool pile is normal. Wool pile should be replaced if gaps between the weather-strip and frame appear.

- Harsh abrasive cleaners should never be used on frames or glass surface.

- If products are within 10 miles of the coast, metal surfaces should be cleaned with a fresh water rinse every one to three months. Car wax on the surface will provide some protection. Anodized or painted surfaces will help prolong the life and enhance appearance. Clean and lubricate hardware components with corrosion resistant spray or lubricant monthly to ensure proper performance. Silicone lubricant spray can be used on all operable components.

REMOVAL OF OLD WINDOWS OR DOORS

Some things to keep in mind when removing old products.

- Follow the EPA's Lead Renovation, Repair and Painting Rule (RRP Rule) which requires that firms performing renovation, repair, and painting projects that disturb lead-based paint in homes, child care facilities and pre-schools built before 1978 have their firm certified by EPA (or an EPA authorized state), use certified renovators who are trained by EPA-approved train providers and follow lead-safe work practices. For more information visit www.epa.gov/lead.

- When removing products from a building YDW recommends that you follow local rules and regulations for disposal. Whenever possible, take window and door products or components to reuse or recycling centers and avoid disposing them in the landfill. Consult with your local recycling center for more information on programs in your area.

Installation Instructions: YDW provides installation instructions for common new construction and replacement applications found at www.ydwindowinc.com. Some YDW products have specific installation instructions which are also available on the website. For variations of these installation instructions or questions regarding alternative installation practices, call (209) 323-6850 for more information.

Disclaimer: EPA makes no warranties, expressed or implied, nor assumes any legal liability or responsibility for the accuracy, completeness, or usefulness of the contents of installation instructions, or any portion thereof. Further, EPA cannot be held liable for defects or deficiencies resulting from the proper or improper application of installation instructions.

PLEASE KEEP THESE INSTRUCTIONS IN YOUR HOME OWNER'S PACKET.

I have read the above instructions and understand the manufacturer's recommendations.

.....
(Installer's signature)



P: 209.323.6850

Visit our website at
www.ydwindowinc.com